

Features + Application Information

1. Powder coated steel bracket (50-70 micron ASTM D4138-07a)
2. Load distribution steel washer + embedded steel plates
3. High deflection, low natural frequency
4. Spring / rubber elements color-coded for easy field verification

5. Ozone & water resistant elastomer elements with embedded steel plates and incorporating projected collar to prevent metal to metal contact between rod and bracket
6. Consult spring chart on page 22 for isolator performance data

Dimensional + Model Selection Data

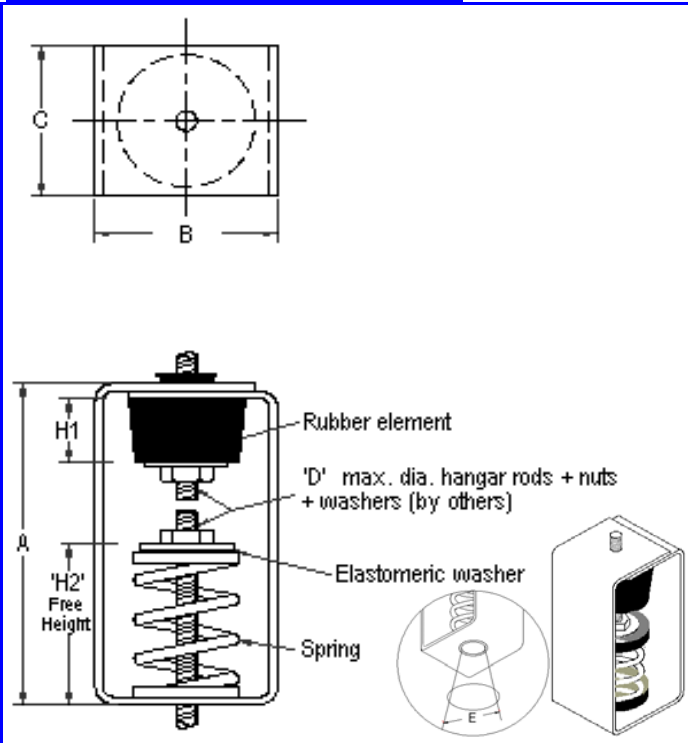

Hanger Series	Dimensions			
	A	B	C	D
HNSF-HM	4.85"	2.15"	1.5"	3/8"
HSB-HM	7-1/2"	3"	2-3/4"	3/8"
HNSA-Ax	8"	3"	2-3/4"	1/2"
HNSA-Bx	8"	3"	2-3/4"	5/8"
HNSB-Ax	10-3/16"	4-1/2"	4"	1/2"
HNSB-B/C/Dx	10-3/16"	4-1/2"	4"	5/8"
HNSE-Ax	11-13/16"	4-1/8"	4"	1/2"
HNSE-B/Cx	11-13/16"	4-1/8"	4"	5/8"
HNSE-Dx	11-13/16"	4-1/8"	4"	3/4"

(Refer to page 2 for isolator star rating system)

1" deflection series ★★☆☆

Model	Load Range (lbs)	H 1	H 2	E
HNSF-HM-041	1 to 15	1"	2.3"	23°
HNSF-HM-042	16 to 35			
HNSF-HM-043	36 to 65			
HNSF-HM-044	66 to 90			
HNSF-HM-045	91 to 185			
HSB-HM-124	131 to 210	1"	3-3/8"	46°
HSB-HM-125	211 to 300			
HSB-HM-126	301 to 370			
HSB-HM-127	371 to 700			
HSB-HM-109	701 to 750			
HSB-HM-110	751 to 910	1"	4-5/8"	28°
HSB-HM-111	911 to 1080			
HSB-HM-112	1081 to 1250			

(Refer to page 2 for isolator star rating system)

1.5" deflection series ★★☆☆

Model	Load Range (lbs)	H 1	H 2	E		
HNSA-A3-121	1 to 50	1-1/4"	3-3/8"	46°		
HNSA-A4-122	51 to 80					
HNSA-B1-123	81 to 130	1-3/4"				
HNSA-B2-124	131 to 210					
HNSA-B3-125	211 to 300					
HNSA-B3-126	301 to 370					
HNSA-B4-127	371 to 582					
HNSB-C3-108	583 to 620	3"			4-5/8"	28°
HNSB-C4-109	621 to 750					
HNSB-C4-110	751 to 910					
HNSB-C4-111	911 to 1080					
HNSB-C4-112	1081 to 1250					
HNSE-D2-158	1251 to 1500		4-1/8"	34°		
HNSE-D2-159	1501 to 2082					
HNSE-D3-159-161	2083 to 2603					

2" deflection series ★★☆☆

Model	Load Range (lbs)	H 1	H 2	E
HSB-HM-140	1 to 80	1"	5-5/8"	28°
HSB-HM-141	81 to 160			
HSB-HM-142	161 to 310			
HSB-HM-143	311 to 410			
HSB-HM-144	411 to 595			
HSB-HM-147	648 to 1190			

2.5" deflection series ★★☆☆

Model	Load Range (lbs)	H 1	H 2	E	
HNSB-A4-140	1 to 80	1-1/4"	5-5/8"	28°	
HNSB-B1-141	81 to 160				
HNSB-B3-142	161 to 310	1-3/4"			
HNSB-B4-143	311 to 410				
HNSB-C3-144	411 to 595				
HNSB-C3-141-146B	596 to 647	3"			n/a
HNSB-C4-147	648 to 1190				
HNSB-D2-148A	1191 to 1576				
HNSB-D2-147-146B	1577 to 1690				28°
HNSB-D2-148A-146B	1691 to 2076				

3.5" deflection series ★★☆☆

Model	Load Range (lbs)	H 1	H 2	E	
HNSE-A4-181	1 to 100	1-1/4"	6-1/2"	30°	
HNSE-B1-182	101 to 150				
HNSE-B2-183	151 to 210	1-3/4"			
HNSE-B3-184	211 to 332				
HNSE-C3-185	333 to 580				
HNSE-C4-186	581 to 850	3"			n/a
HNSE-C4-187	851 to 1157				
HNSE-D2-186-199	1158 to 1470				
HNSE-D2-187-199	1471 to 1825				